

Filler capacity:

Capsule size :

Serial :



MADE IN BELGIUM

FETON INTERNATIONAL SRL

**DATASHEET**

**FULL METAL FILLER 200/300/400**

Rue de la Croix du Maieur, 8 - 7110 Strépy-Bracquegnies - Belgium

Tel : +32-2-420 52 00 / contact@feton.com

TVA BE 0674 542 750 / ING BE07-3630665252-66 / BIC : BBRUBEBB





## FETON International SRL

 **Rue de la Croix du Maieur, 8  
7110 Strépy-Bracquegnies.  
Belgium**

 **Tel : +32-2-420 52 00**

 **contact@feton.com**

---

TVA BE 0674 542 750  
ING BE07-3630665252-66  
BIC : BBRUBEBB

## CONTENTS

<b>1</b>	<b>PRODUCT PRESENTATION</b>	<b>5</b>
<b>2</b>	<b>SAFETY INFORMATION AND DISCLAIMER</b>	<b>5</b>
<b>3</b>	<b>TECHNICAL DATA</b>	<b>6</b>
<b>4</b>	<b>HOW TO USE</b>	<b>8</b>
<b>5</b>	<b>HOW TO CLEAN</b>	<b>11</b>

## 1 PRODUCT PRESENTATION

- Each machine does one single capsule size.
- Only metallic plates and frame.
- Fill Capsule sizes 000, 00, 0, 1, 2, 3, 4 and 5\*.
- No adjustment necessary.
- 200, 300 and 400 Capsules capacity.
- Very robust design.
- Easy to clean.

\* Only for Full kit Metal 200.



FMT200



FMT300



FMT400

## 2 SAFETY INFORMATION AND DISCLAIMER

All material should be cleaned before every use. (refer to section 5)

Many parts are heavy and might cause injury if mishandled or in case of fall.

Always work on a stable and flat surface, at a height that is comfortable to work while standing. Have sufficient free space around the machine you are working with.

As the filling is manual, results may vary depending on the user. Other factors can influence the results such as but not limited to: type of powder, number of tamps, filling weight, capsule size, vibration type and intensity. It is the responsibility of the user to make sure the prescribed dose is respected. Feton International is not responsible for wrong dosing.

Illustrations, descriptions and specifications are not contractual and are subject to change without prior notice.

Feton International Srl declines all liability in the event of improper use of its products.

## 3 TECHNICAL DATA

### 3.1 COMPONENTS LIST AND MATERIALS

**NOTE :** The Filler presented in the images below is the 200-size.  
 The same names and principles apply for the 300- and 400-sizes.

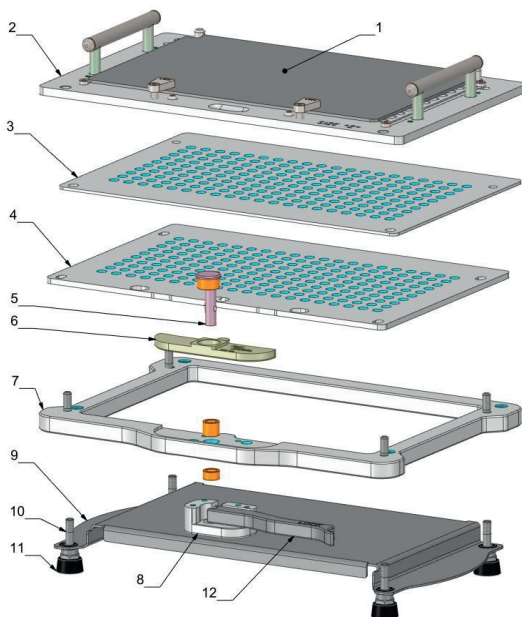

Item N°	Quantity	Name	Material
1	1	Lid	316 Stainless Steel
2	1	Top plate 6mm	Anodised Aluminium
3	1	Filling Plate 2mm	316 Stainless Steel
4	1	Bottom Plate 4mm	316 Stainless Steel
5	1	Eccentric Pin	304 Stainless Steel
6	1	Pusher	304 Stainless Steel
7	1	Frame	304 Stainless Steel
8	1	Bloc pusher	304 Stainless Steel
9	1	Base Plate	316 Stainless Steel
10	4	Foot	304 Stainless Steel
11	4	Foot	Rubber
12	1	Lever	304 Stainless Steel

### 3.2 DIMENSIONS AND WEIGHT

<b>Number of Capsules</b>
200
<b>Capsules Sizes options</b>
000-00-0-1-2-3-4-5*
<b>Weight</b>
5,8kg

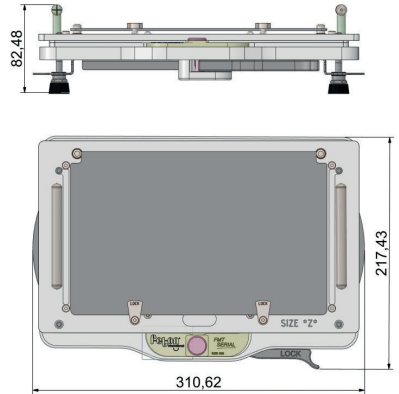

<b>Number of Capsules</b>
300
<b>Capsules Sizes options</b>
00-0-1-2-3-4
<b>Weight</b>
7,8kg

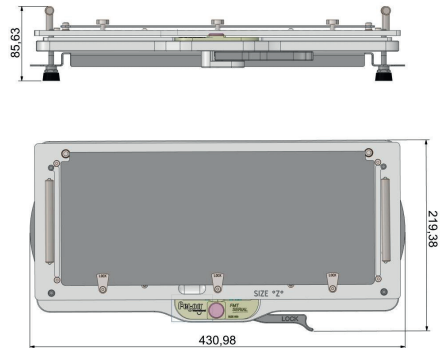

<b>Number of Capsules</b>
400
<b>Capsules Sizes options</b>
00-0-1-2-3-4
<b>Weight</b>
9,8kg

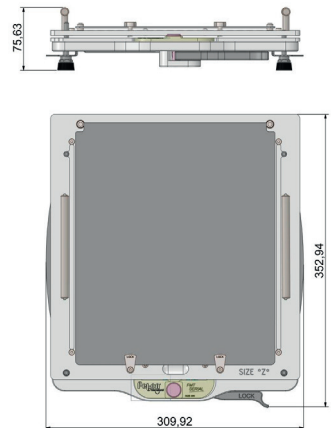

\* Only for Full kit Metal 200.

## 4 HOW TO USE

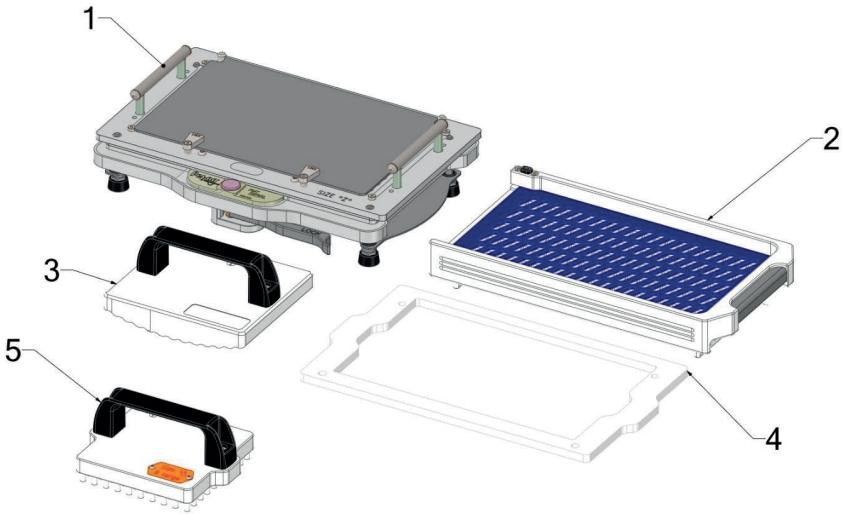

Item N°	Quantity	Name	Material
1	1	Capsule Filler	See 3.1
2	1	Capsule Loader (optional)	POM and PMMA
3	1	Serial Closer (optional)	POM
4	1	Modular Powder Stop (optional)	PMMA
5	1	Tamper (optional)	POM

**NOTE :** Operate your capsule filler at least one time without filling the capsules (steps 3-4-5-8) at the start of every preparation. This will allow you to check that everything is working correctly.

*See table below for visual instructions. (p.09-10)*

1. Prepare your material. Install the plates in this order: Bottom Plate, Filling Plate, Top Plate.

2. Load the Capsules. Please refer to the Loader datasheet for detailed instructions.



3. Pull the Lever to lock the Capsules' bodies.
4. Pull the Top Plate upwards, starting from the back side for easier separation. Push with your palms on the Handles and pull with the fingers on the Top Plate.
5. Release the Lever. If needed, push on the Capsules's bodies so that they are flush with the Filling Plate.
6. Fill the Capsules. Use of a Powder Stop is optional.
7. If needed, you can use a Tamper to push the powder into the Capsules to be able to fill a higher volume.
8. Place the Top Plate. Pull the Base Plate to push the Capsules' bodies into the Capsules' heads. The capsules are now "pre-closed".
9. Take the Top Plate and turn it upside down on your table. If you have a Serial Closer, use it to close the Capsules in two, three or four motions (depending on if you have a 200, 300 or 400). If you do not have a Serial Closer, close the capsules by hand.
10. Your Capsules are now ready.

1

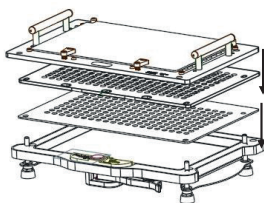

2

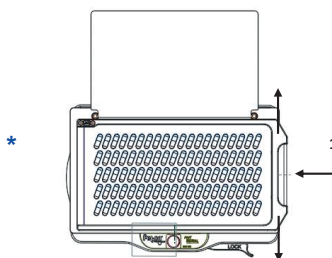

- \* Optional accessory : Loader 200 : REF : CH200-\*\*\* / Loader 300 : REF : CH300-\*\*\* / Loader 400 : REF : CH400-\*\*\*
- \*\* Optional accessory : Powder Stop for FMT200 : REF : APR 200 / FOR FMT300 : REF : APR 300  
/ FOR FMT400 : REF : APR 400
- \*\*\* Optional accessory : Tamper 100 : REF : TAS100CR-\*\*\* / 120 : REF : TAS120CR-\*\*\*  
(size 00 to 4 - 1 tamper per capsule size)
- \*\*\*\* Optional accessory : Serial Closer : REF : SECL-0/1/2/3/4/5 or SECL-000/00

3

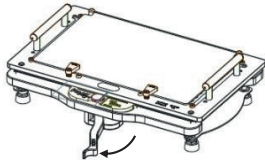

4

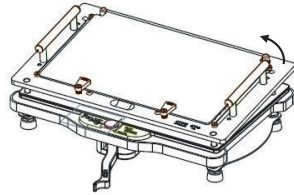

5

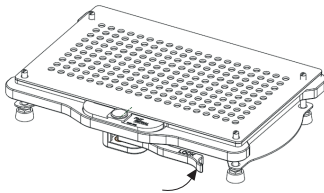

6

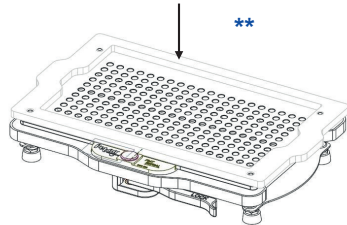

7

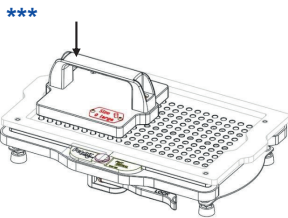

8

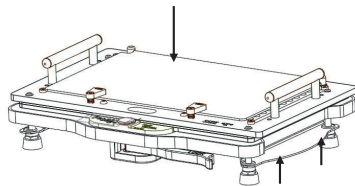

9

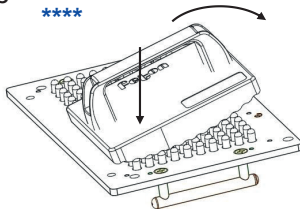

10

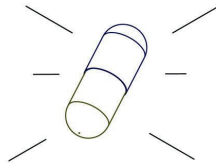

\* Optional accessory : Loader 200 : REF : CH200-\*\*\* / Loader 300 : REF : CH300-\*\*\* / Loader 400 : REF : CH400-\*\*\*

\*\* Optional accessory : Powder Stop for FMT200 : REF : APR 200 / FOR FMT300 : REF : APR 300 / FOR FMT400 : REF : APR 400

\*\*\* Optional accessory : Tamper 100 : REF : TAS100CR-\*\*\* / 120 : REF : TAS120CR-\*\*\*  
 (size 00 to 4 - 1 tamper per capsule size)

\*\*\*\* Optional accessory : Serial Closer : REF : SECL-0/1/2/3/4/5 or SECL-000/00

## 5 HOW TO CLEAN

**It is important** to clean the parts in contact with the capsules or the powder thoroughly between each use to avoid contamination. Cleaning can be done by hand, in a dishwasher or in an autoclave. If done by hand, use warm water and soap.

- All metal parts : Use a maximum temperature of 110°C/230°F.
- All plastic parts : Use a maximum temperature of 40°C/104°F.

If you have difficulties cleaning the inside of the holes on the plates, use the small Feton-cleaning brush :



REF. BRU

### For information - Note for aluminium parts :

If done in a dishwasher or in an autoclave, do not use alkaline or acid cleaning product that are not suitable for treated aluminium anodized, as they oxidize the surface treatment of the plates which could deteriorate or change color.

Example of unsuitable products :

- Base : Alkaline detergent
  - For anodized parts not suitable for  $\text{pH} > 7$
- Acids : Hydrogen peroxide
  - For anodized parts not suitable for  $\text{pH} < 4$

In general, use cleaning products whose  $\text{pH}$  is neutral.

Please refer to the technical datasheet of your cleaning product to check whether it is suitable or not.

**NOTE :** Just because the surface treatment has changed color slightly does not mean the plate is eligible for a return under warranty.

### pH-scale :

